

Manhole Castings L-27

800-EJP-24 HR

Extension Rings

Round Extension Rings



Extension rings are designed to raise the height of the manhole cover or grate without having to raise the frame. One man can quickly install an extension ring, adjust it and replace the cover.

BENEFITS:

- Saves time and money
- Lightweight and easy to install
- Adjustable for tight fit and close tolerance
- Available in 1", 1½", 2" and 2½" heights

FABRICATED STEEL SPECS:

- ASTM 36 Hot Rolled steel for long life. Other grades available
- All welding to American Welding Society specifications. Top has continuous welding and the bottom has stitch welding.
- Tolerance $\pm 1/16$ inch (not cumulative)
- Coated with black asphalt paint.
- There are no inclusions or slag
- Adjusting screw is made of 304 stainless steel.

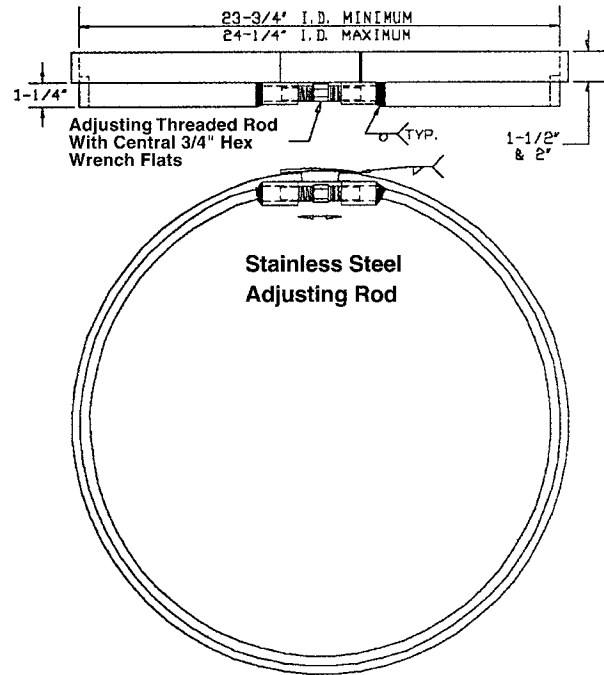

ORDERING INFO:

- Various designs to meet all street situations. For best possible fit, please supply the following information:
 - Cover diameter
 - Cover thickness
 - Frame seat inside diameter
 - The height of rise

DESCRIPTION	PRODUCT NUMBER	
	LeBaron	QWP
24" x 1" Round MH Riser Ring	66100	62004 600*
24" x 1.5" Round MH Riser Ring	66100 1	62005 600*
24" x 2" Round MH Riser Ring	66100 2	62006 600*
24" x 2.5" Round MH Riser Ring	66100 3	—
26" x 1" Round MH Riser Ring		62006 1 600*
26" x 1.5" Round MH Riser Ring		62007 600*
26" x 2" Round MH Riser Ring		62008 600*
32" x 1.5" Round MH Riser Ring		62009 1 600*
32" x 2" Round MH Riser Ring		62009 2 600*

* 24" rings have an adjustment of 23¾" to 24¼"

* 26" rings have an adjustment of 25¾" to 26¼"

* 32" rings have an adjustment of 31¾" to 32¼"