

B-Too™ Drilling and Tapping Machine



B-TOO™ DRILLING AND TAPPING MACHINE COMPLETE

PRODUCT NUMBER

63527

How to Order:

1. Order the Basic B-Too™ Drilling Machine.
2. Order Drills and Taps necessary for range of desired cuts and pipe materials (see page N-19).
3. Order Screw Plugs with threads matching the body outlet threads of the corporation stops used (see page N-19).
4. Order a pipe saddle from this page for each size of pipe the B-Too™ will be used on. One extra chain section is required for 18"–30" mains, two extra chain sections are required for 32"–48" mains (part #26 page N-20).
5. Order extra tapping compound if needed (see page N-21).

For Insertion of 1/2"-1" Corporations Under Pressure

With the B-Too™ Drilling and Tapping Machine you can...

1. Insert any corporation stop under pressure.
2. Extract threaded corporation stops from the main and insert a main plug.
3. Extract a defective threaded corporation stop from the main and insert a new corporation stop (3/4" size only).

Check Out These Money and Time Saving Features:

- Lighter and easier to handle than other machines.
- Fast — no disassembly and reassembly during installation.
- No chip problems or water loss.
- Simple and easy to operate, manually or with power.
- Can be preloaded under cover in foul weather.
- Low maintenance cost.
- Reduces installation time to save costs.
- You buy only the parts and tools required for your jobs.
- Made of high strength modular aluminum and steel components which hold up under stress to provide long service life.
- Uses your existing pipe saddles, drill taps, ratchets, chain holders, chains and screw plugs.

Pipe Saddles

B-TOO™ PIPE SADDLES	SADDLE SIZE	PRODUCT NUMBER
	2"	63527 53
	3"	63527 54
	4"	63527 55
	6"	63527 56
	8"	63527 57
	10"	63527 58
	12"	63527 59
	14"	63527 60
	16"	63527 61
	18"	NA
20"	63527 62	
24"	63527 63	

B-Too™ Drilling and Tapping Machine

Combined Drills and Taps

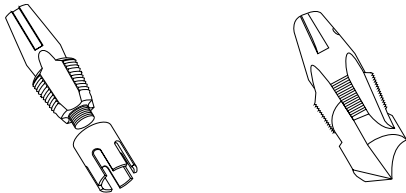

TYPE OF PIPE	THREAD TYPE	TAP SIZE	PRODUCT NUMBER
PVC PIPE	AWWA	1/2"	N/A
		5/8"	N/A
		3/4"	63528 217
		1"	63528 219
	HOLE CUTTER	1/2"	N/A
		5/8"	N/A
3/4"		63528 218	
CI, DI & AC PIPE	IRON PIPE	1"	63528 220
		1/2"	63528 221
		5/8"	N/A
	AWWA	3/4"	63528 222
		1"	63528 223
		1/2"	63528 224
		5/8"	63528 225
		3/4"	63528 226
		1"	63528 227

B-Too™ Quik Release Screw Plugs

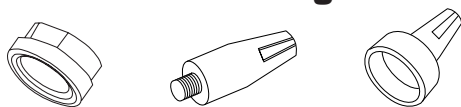

DESCRIPTION	SIZE	PRODUCT NUMBER
Screw Plug Body 3/4" & 1"	—	63527 39
Screw Plug Flare/Comp. Copper	3/4"	63527 44
Screw Plug FIP	3/4"	63527 45
Screw Plug MIP	3/4"	63527 46
Screw Plug Drive Thread	3/4"	63527 47
Screw Plug Mueller 110 IPS	3/4"	63527 52
Screw Plug Flare/Comp. Copper	1"	63527 40
Screw Plug MIP	1"	63527 41
Screw Plug Drive Thread	1"	63527 42
Screw Plug FIP	1"	63527 43
Screw Plug Mueller 110 IPS	1"	63527 51
Screw Plug Body 1 1/4"	1 1/4"	63527 48
Screw Plug Flare/Comp. Copper	1 1/4"	63527 49
Screw Plug FIP	1 1/4"	63527 50

With the B-Too™ Drilling and Tapping Machine, corporations are installed under pressure in four simple steps.

1) Load Drill and Tap

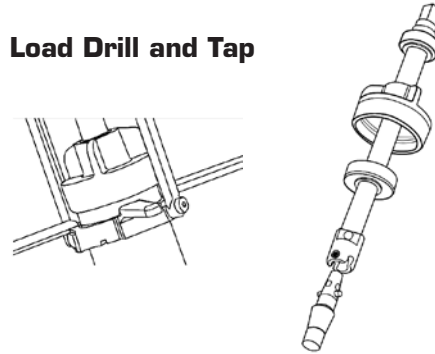

2) Mount on Pipe

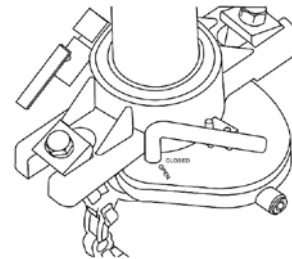

3) Tap or Drill

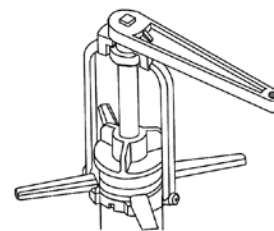

4) Prepare Corporation Stop and Insert

